



Industries

Ri-Treat

Waste water treatment system

South Australia's leading manufacturer of pre-cast concrete products including Ri Treat waste water treatment, trades waste arrestors, septic tanks and rainwater tanks

www.ri-industries.com.au



**Leaders in pre-cast concrete products
that enhance the environment**

Ri-Industries was established 1947.
We are totally committed to achieving
excellence in all that we do, which is
why South Australian residents and
businesses repeatedly buy our products
and regularly recommend us.

www.ri-industries.com.au

618 South Rd, Angle Park, SA 5010
P (08) 8444 8100 F (08) 8268 2335

About Ri Industries

Specialists in pre-cast concrete products since 1947.

Ri-Industries manufactures and supplies pre-cast concrete products. Since 1947 we have established a strong reputation for the quality of our products, service, and our knowledge, in particular, of septic tanks, waste water treatment and rainwater tanks. We are totally committed to achieving excellence in all that we do, which is why South Australian residents and businesses repeatedly buy our products and regularly recommend us.

For homeowners our Ri-Treat waste water treatment system is considered to be the finest in Australia. The same goes for our concrete septic tanks and concrete rainwater tanks. If you want a product that is of the highest quality with trouble-free maintenance then you want Ri Industries pre-cast concrete septic tanks, rainwater tanks and wastewater treatment systems.

Our wastewater treatment systems help you save water with the garden and lawn irrigation system that is included.

For businesses we offer Ri-Cycle, a commercial version of our waste water treatment system, trade waste arrestors, stormwater sumps and grates and frames, and covers. We also work regularly with civil engineering and construction companies to provide tailored pre-cast concrete solutions such as retaining wall panels, bridge parapets, pre-cast beams and arch tunnels. If you have a special project needing pre-cast concrete, we can provide the solution.

Committed to excellence

From our base in Angle Park, South Australia, we have made it our life's work to deliver outstanding pre-cast concrete products. We are committed to excellence, not only in our manufacturing techniques and processes but through every interaction we have with our customers.

We are South-Australian owned and operated and we service all parts of metropolitan Adelaide, rural and regional areas within SA and the Northern Territory.

Ri-Industries was the first South Australian company to combine the manufacture, delivery and placement of septic tanks. With engineering experience that spans over 60 years, we have developed a number of associated products to deal with sewage and waste, most notably our Ri-Treat system. Our unique design has become a leader in South Australia for the management and treatment of waste water.

All of our products are 'over-engineered'. That is how we strive for 100% excellence. Plumbers describe our products as "second-to-none" and "the best in South Australia". We are proud of our stand-out quality of product and service. This is further backed up by our on-time deliveries, knowledgeable sales team and after sales back-up services.

Ri-Treat waste water treatment system



**Reclaim your waste water by recycling
and reusing water around the home**

- Guaranteed superior quality
- Engineer-designed and SA manufactured
- FREE onsite visit to find the best location for your tank



The best waste water treatment system

The design of the Ri-Treat waste water treatment system is unique to Ri-Industries. Proudly South Australian, we have manufactured pre-cast concrete tanks and products since 1947.

Our environmentally friendly waste water treatment system is guaranteed to be of superior quality. Our customers repeatedly tell us that "Ri-Industries products are the best in South Australia."

Choosing a Ri-Treat waste water treatment system gives you a number of advantages:

- A mono cast 50 MPa reinforced concrete construction, with no fibreglass or plastic structural components, means that **no untreated effluent will escape into the environment.**
- The high quality bio filter medium enhances the **purity of the recycled water.**
- All irrigation pumps are Lowara or Grundfos 316 stainless steel, and are **submersible, quiet, reliable and inexpensive to operate.**
- The Japanese Nitto Air Pump offers the most **reliable and efficient aeration** and has a **3 year warranty.**
- Ri-Treat tanks come in three sizes, offering **maximum flexibility** and even allow for an internal spa bath.
- Child-proof and vandal-proof lids give you additional **peace of mind.**
- A high quality irrigation kit for **more effective irrigation.**
- The septic **tank is sealed** as an additional precaution.
- We offer a **manufacturer's warranty** on the tank construction.

The operation of the unit has other unique features, such as automatic sludge and skimmer returns.

"...It's heartening that there are still companies who live up to their claims... I'd recommend Ri-Industries to anyone who asks."

Home owner, Victor Harbor

What you get

When you purchase a Ri-Treat waste water treatment system, you receive:

- A mono cast Ri-Treat system in one of three sizes: 3250, 4250, or 4500.
- A Lowara DIWA or Grundfos stainless steel pump (supplied and fitted).
- A Japanese Nitto linear aeration pump (supplied and fitted).
- An internal alarm panel and external control box.
- A 12 month service contract – commissioning the system and the first three services are included in the price of the system.
- An irrigation kit consisting of 50 metres of 25mm poly pipe and 10 above ground sprinklers. Extra sprinklers can be added if required.
- Painted and sealed tank tops.
- Delivery of the unit and placement in the excavated hole (at drivers' discretion).
- Five council-approved reclaimed water signs.

We can also provide a FREE on-site visit to advise on tank location and delivery assessment – saving you trouble and money.

Our waste water treatment systems come in three sizes:

Type	Capacity	Diameter	Height	Invert (height)	Approx weight
3250	6 people + spa bath	2500mm	2460mm	1700mm	6,565kg
4250	8 people + spa bath	2500mm	2760mm	2150mm	7,100kg
4500	9 people + spa bath	2500mm	3060mm	2280mm	7,350kg

BELOW GROUND





How it works

The Ri-Treat system separates and digests solid wastes and uses natural processes to purify wastewater. This odourless, clean, disinfected water is then recycled through garden sprinklers.

- 1 All waste water and effluent is gravity-fed into primary sewage chambers where it undergoes settlement and digestion for a minimum of 24 hours.
- 2 Settled waste water then flows into aeration chambers where air is pumped through in fine bubbles, providing the distribution of air and turbulence required for effective treatment.
- 3 Turbulence causes liquids to travel in a circular motion through the bio filter medium which encourages biomass growth. The biomass assimilates nutrients and oxygen from the water, leading to a reduction of impurities as the effluent passes through the system.
- 4 Effluent and sludge then pass into the settlement chamber, where the sludge settles to the bottom before being returned to the primary chambers, along with the scum which floats in the settlement chamber.
- 5 Settled effluent passes through the chlorinator into the irrigation chamber where it is held for irrigation or other means of disposal.

After being treated in our underground tanks, household waste from the toilet, bathroom, kitchen and laundry can be re-used to irrigate your garden.



Suitable plants

The list below is a guide to suitable plants for the surface irrigation disposal area. Please note, due to wide climatic and soil variations, you should check with your local plant nursery before finalising your plant choice.

Trees

<i>Botanical name</i>	<i>Common name</i>	<i>Approx. height</i>
Agonis Flexuosa	Willow Myrtle	5 - 6 metres
Acacia Baileyana	Cootamundra Wattle	3 - 5 metres
Banksia Spp.	-	3 - 10 metres
Casuarina Glauca	Swamp Oak	6 - 12 metres
Casuarina Stricta	Drooping She Oak	3 - 5 metres
Casuarina Cunninghiana	River She Oak	6 - 10 metres
Callistemon Viminalis	Red Bottlebrush	3 - 6 metres
Callistemon Salignus	White Bottlebrush	3 - 6 metres
Eucalyptus Robusta	Swamp Mohogany	6 - 9 metres
Eucalyptus Saligna	Sydney Blue Gum	15 - 20 metres
Eucalyptus Grandis	Flooded Gum	10 - 20 metres
Eucalyptus Camaldulensis	River Red Gum	15 - 20 metres
Eucalyptus Cosmophylla	Cup Gum	5 - 6 metres
Hymenosporum Flavum	Native Frangipani	3 - 6 metres
Leptospermum Laevigatum	Coast Tea Tree	5 - 6 metres
Melaleuca Armillaris	Bracelet Honey Myrtle	3 - 4 metres
Malaleuca Quinquenervia	Broad Paperback	5 - 7 metres
Melaleuca Nesophila	Western Tea Myrtle	2 - 4 metres
Pittosporum Spp.	-	2 - 4 metres
Syzygium Paniculatum	Bush Cherry	8 - 10 metres
Tristania Laurina	Kanuka	3 - 5 metres

Shrubs

<i>Botanical name</i>	<i>Common name</i>	<i>Approx. height</i>
Abelia X Grandiflora	Abelia	2 - 3 metres
Acacia Floribund	Gossamer Wattle	2 - 4 metres
Acacia Longifolia	Sallow Wattle	2 - 4 metres
Acacia Iteaphylla	Flinders Range Wattle	2 - 3 metres
Cotoneaster Spp.	-	2 - 4 metres
Cortaderia Selloana	Pampas Grass	2 - 3 metres
Cyperus Alternifolius	Umbrella Grass	0.5 - 1 metre
Cyperus Papyrus	Papyrus	1 - 2 metres
Cassia Spp.	Swamp Mahogany	1 - 3 metres
Chamelaucium Uncinatum	Geraltan Wax	2 - 4 metres
Dryandra Formosa	-	1 - 3 metres
Eremopjhila Spp.	-	1 - 2 metres
Grevillea Spp.	-	1 - 3 metres
Hebe Spp.	Veronica	0.5 - 1 metres
Iris Pseudacorus	Yellow Flag Iris	0.5 - 1 metres
Nerium Oleander	Oleander	2 - 3 metres
Melaleuca Decussata	Cross Leaved Honey Myrtle	1 - 2 metres
Phormium Tenax	New Zealand Flax	2 - 2.5 metres

Perennials / Ground cover

<i>Botanical name</i>	<i>Common name</i>	<i>Approx. height</i>
Aster Novi-gelgii	Perennial Aster	0.5 - 1 metre
Canna	-	1 - 2 metres
Chrysanthemum Frutescens	Marguerite Daisy	1 metre
Chrysanthemum Maximum	Shasta Daisy	1 metre
Gazania Ringens	Black Eyed Susan	0.4 metres
Impatiens Spp.	-	0.4 metres
Salvia Uliginosa	Bog Salvia	0.4 metres
Viola Spp.	-	0.4 metres

Climbers

<i>Botanical name</i>	<i>Common name</i>	<i>Approx. height</i>
Bougainvillea Spp.	-	Variable
Clematis Spp.	-	Variable
Hardenbergia Violacea	Purple Coral Pea	Variable
Hibbertia Scandens	Snake Vine	Variable
Jasminum Grandiflorum	-	Variable
Jasminum Polyanthum	-	Variable
Jasminum Officinale	Common Jasmin	Variable
Kennedia Rubicunda	Dusky Coral Pea	Variable
Lonicera Japonica	Japanese Honeysuckle	Variable
Passiflora Spp.	Passion Flower	Variable
Vitis Coignetiae	Glory Vine	Variable

"I find it staggering that out of over 500 tanks purchased from Ri-Industries I haven't received a single complaint. Their products are the best in South Australia."

SA plumber



Maintenance

Your Ri-Treat system will be effective for more than 30 years, providing it is used and maintained in the correct manner.

When you buy a waste water treatment system from Ri-Industries we provide you with a maintenance manual. This details your maintenance schedule and outlines remedies in the unlikely event of problems. Normally, problems are only ever encountered in extreme circumstances like overloading with solid wastes and intrusion of things like rags, newspapers, oils and scraps.

It is mandatory that you service your system every three months to ensure consistent performance and compliance with the South Australian Health Commission. This will check the operation of pumps, chlorination, aeration and irrigation systems.

The cost of your first four services (eg. commissioning the system and a further three services) is included in the cost of your Ri-Treat waste water treatment system.



Warranties

We are extremely confident in our products, and offer extensive warranties:

Tanks – manufacturer’s warranty on construction

Controls – **3 years**

Air and submersible pumps – **3 years***

**The irrigation pump warranty has been extended from the manufacturer’s standard 1 year warranty because of the high quality effluent being passed through the system. The Nitto air pump normally runs 24 hours per day and uses approximately 85 watts of power per hour (equivalent to a normal light globe).*



Installation

Most plumbers and drain layers in South Australia are familiar with the Ri-Treat waste water treatment system. Contact us for a list of plumbers and drain layers in your area.

For your convenience please tear out the Electrical Installation and Circuit Diagram on the back page and pass to your electrician as soon as possible before installing the system.



Ri-Treat systems

Important installation notes:

- Hole excavation is minimum 3m x 3m square.
- If base is rocky or uneven you will require road or gravel base. Do not backfill with rocky soil as damage may occur.
- SA Department of Health regulations state the lid must sit above ground level at the seal.
- Tanks must be half filled with water through sewer inlet (all chambers) to stop flotation.

Ri-Treat increments:

- 300 - 465kg
- 450 - 600kg
- 600 - 760kg

3250 Ri-Treat
6 person
3 bedroom
6,565kg



4250 Ri-Treat
8 person
4 bedroom
7,100kg



4500 Ri-Treat
9 person
5 bedroom
7,350kg



Delivery

We offer a FREE on-site visit to advise on tank location and delivery assessment.

Delivery instructions

The truck would need to reverse up to the hole. A clear level site is required to unload the tank into your prepared excavation. Easy access is very important, ie. NO overhead trees, wires, etc. NO benching out of the hole.

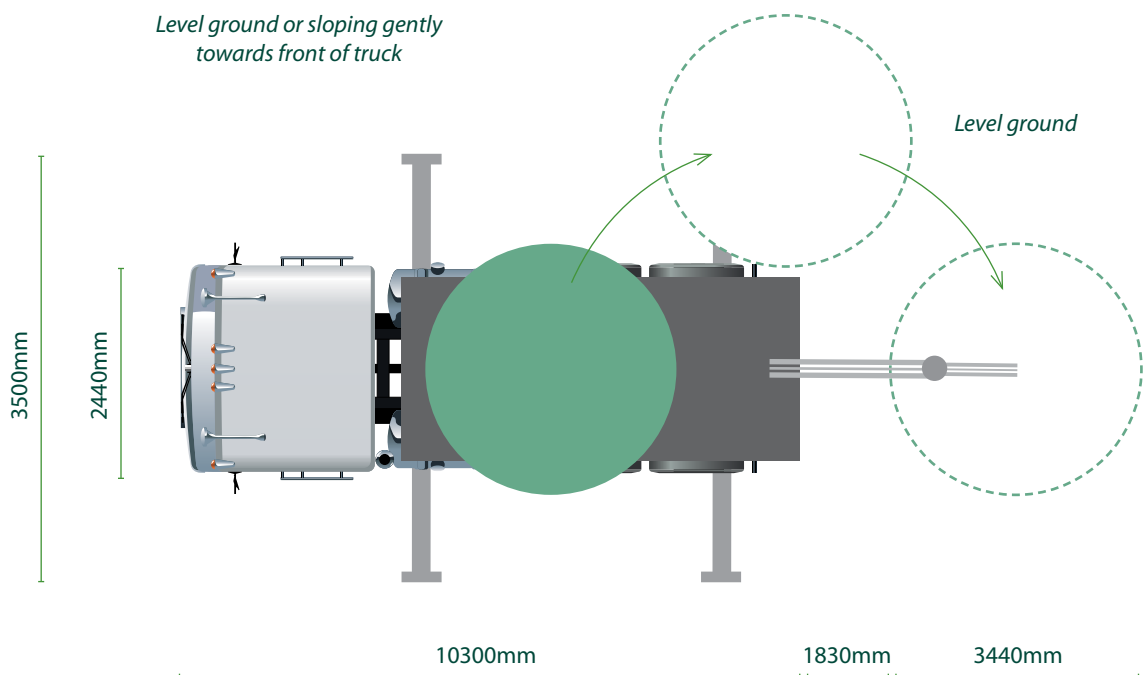
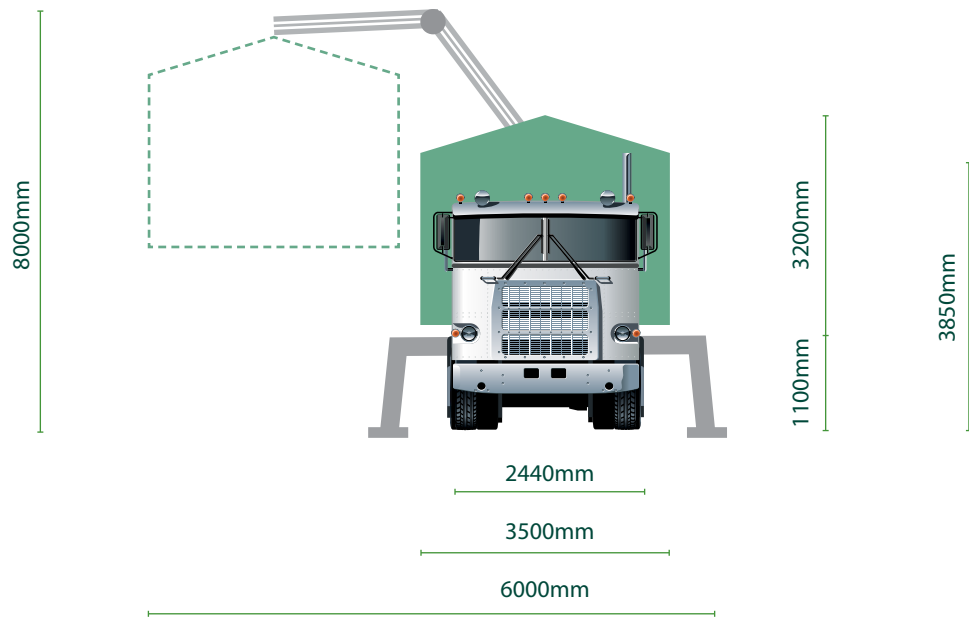

Electrical installation

For your installing plumber

All electrical connections must be carried out by tradespersons who are experienced and licensed for such work.

Within the premises switchboard, we recommend the use of an independent and dedicated circuit of 16 Amp (minimum) being serviced with its own ELCB (residual current device) to supply power to your Ri-Treat waste water treatment system.

Note: Ri-Industries' alarm panels will reset automatically and are 12 volt AC powered from a transformer within the control box mounted to the top of the tank. The green light indicates that there is power to the system. Low voltage for **your safety**. Auto reset for the least inconvenience and peace of mind.

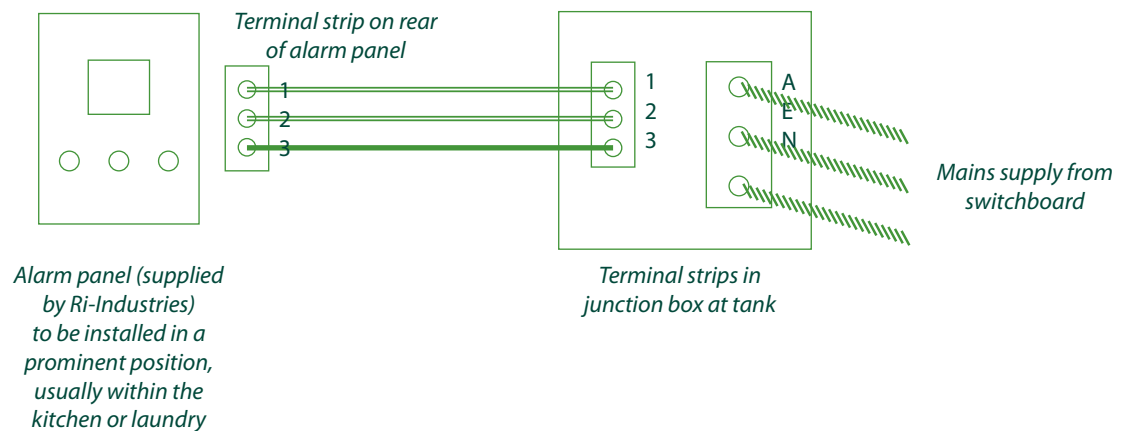
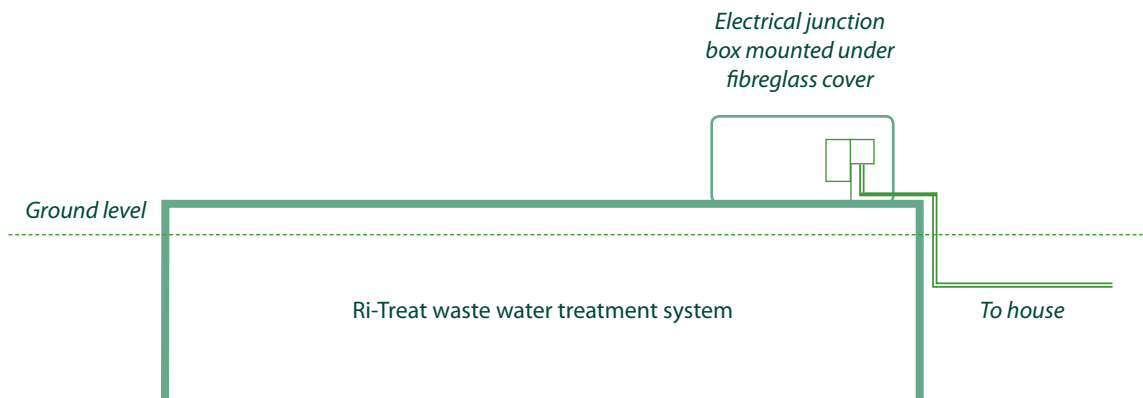



Industries

**Leaders in pre-cast concrete products
that enhance the environment**

Ri-Industries was established 1947.
We are totally committed to achieving excellence
in all that we do, which is why South Australian
residents and businesses repeatedly buy our
products and regularly recommend us.

www.ri-industries.com.au

618 South Road, Angle Park, South Australia, 5010

P (08) 8444 8100 F (08) 8268 2335

abn 81 007 647 323

