

# Ri-Scape tank • 3,300 litre with 900L pump chamber

Item	Approx Mass
3,300 litre Ri-Scape tank	3,200kg

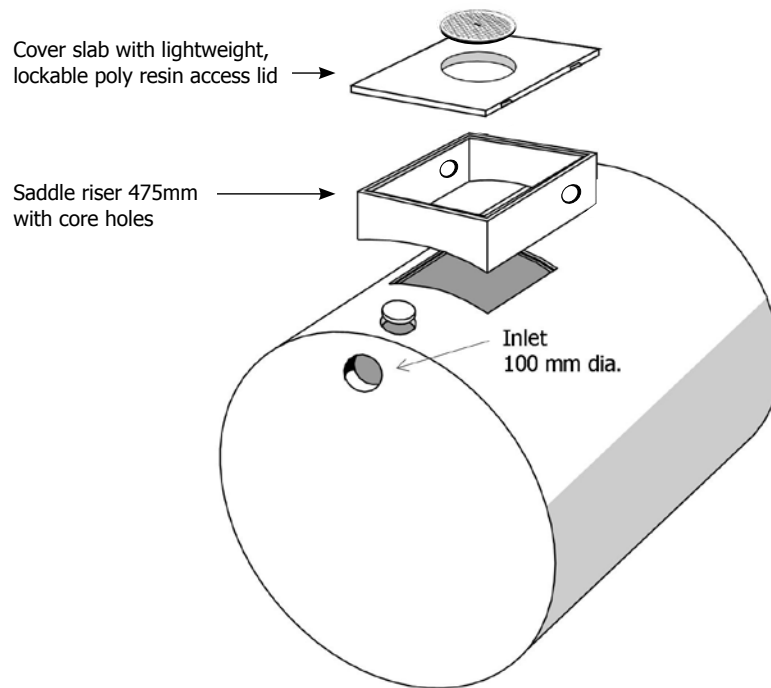

The tanks have been designed to be buried with the top of the tank located 900mm maximum below ground level and with the cover slab at ground level.

