



Ri-Industries

For servicing of your STS unit please
telephone the service agent.

Installation and Maintenance Manual

RI-TREAT EP10 SECONDARY TREATMENT SYSTEM

South Australia's leading manufacturer of
pre-cast concrete products, including secondary
treatment systems, trade waste arrestors,
septic tanks and rainwater tanks.





Ri-Industries

Contents

| | |
|----------------------|----|
| WARRANTY | 3 |
| PREPARATION | 4 |
| EXCAVATION | 5 |
| DELIVERY | 6 |
| INSTALLATION | 7 |
| ELECTRICAL | 8 |
| COMMISSIONING | 9 |
| SERVICING | 10 |
| BRISTLE FILTER | 14 |

ri-industries.com.au

24-30 Davis Street, Wingfield,
South Australia, 5013

(08) 8444 8100

Warranty

The warranty will be void if the unit is not installed, maintained, or operated according to the manufacturer's requirements. Examples include:

- Failure to install the tank in strict accordance with the Ri-Industries Installation and Maintenance Manual for the Ri-Treat EP10.
- Any form of structural modification.
- Failure to service the aerobic unit in compliance with SA Health guidelines for onsite wastewater systems and the manufacturer's specified requirements.
- Failure to undertake servicing and repairs by an approved SA Health servicing contractor or failure to maintain records of all services and repairs.
- Overloading the system by not following the guidelines outlined in the General Information section of the Ri-Industries Householders Operational Manual for the Ri-Treat EP10.
- Use of unsuitable cleaning products, as specified in the Ri-Industries Householders Operational Manual.
- Damage to the unit caused by (but not limited to) planting too close to the tank or external forces such as storms, fires, and floods.
- Failure to provide full system details during the transfer of ownership or land development.

Copies of the Householders Operational Manual and the Installation & Maintenance Manual can be found online at www.ri-industries.com.au.



Preparation

Preparation for the delivery and installation of a Ri-Treat EP10

- The Ri-Industries crane truck requires full and clear access to the site and around the excavation.
- Site conditions should be dry and stable underfoot, with a level set-up area prepared for the truck.
- The crane truck will reverse up to the excavation, lift, and move the tank into position over the rear axle.

Note: Under no circumstances will concrete tanks be lifted over houses, sheds, or other valuable property, nor will they be lifted under low power lines. Unloading on difficult or hazardous sites will be at the driver's discretion.

Ri-Treat EP10 • 6565kg



Excavation

Preparation for excavation

- The excavation area must be a minimum of 3 metres x 3 metres.
- Over-excavate by at least 300mm on all sides for backfill.
- To prepare the base, excavate a flat, uniform surface 100mm below the required level and backfill with 10–12mm gravel for tank bedding.
- If the natural ground is extremely soft, over-excavate by 200mm, compact 100mm of 50–75mm ballast into the surface, and backfill to the required level with 10–12mm gravel.
- **Do Not** place the unit on a rocky or uneven base.



Delivery

We offer a FREE on-site visit to advise on tank location and delivery assessment.

Delivery Instructions

The truck will need to reverse up to the excavation. A clear, level site is required to unload the tank into the prepared hole. Easy access is essential - no overhead trees, wires, or other obstructions. Benching out of the hole is not permitted.

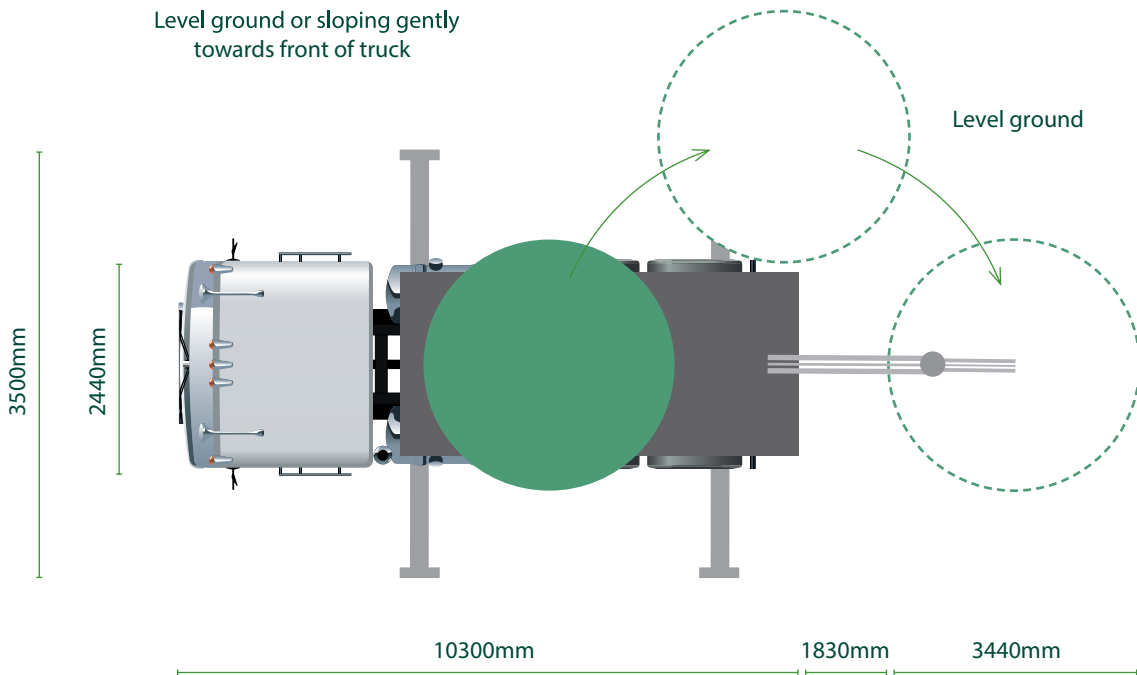
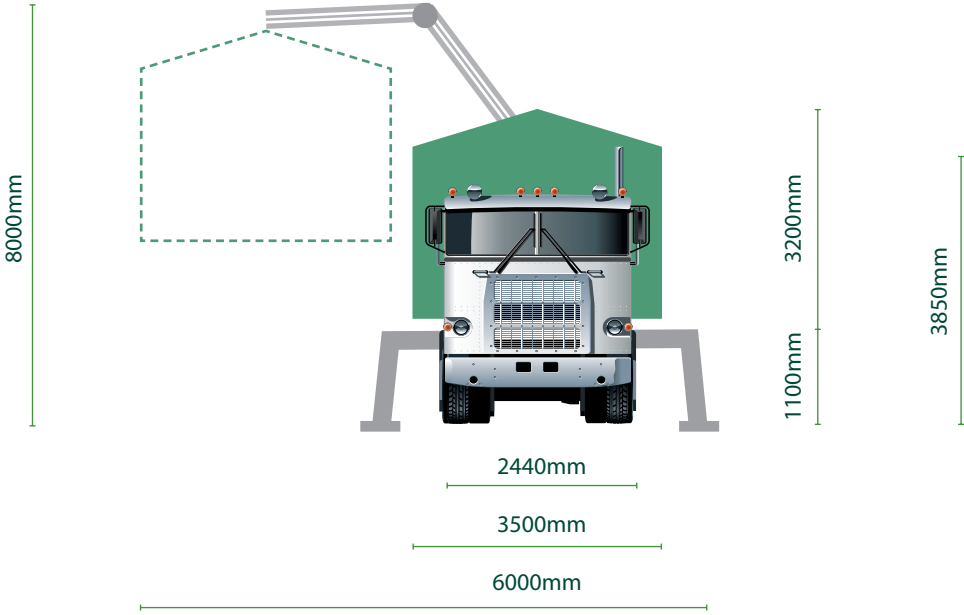

Installation

All Ri-Treat EP10 units are factory water-tested in a controlled environment before delivery.

- **The Ri-Treat EP10 must be installed by a licensed plumbing contractor.**
- The tank must be level when installed, with the lid sitting above ground level at the seal.
- **Do not fill the EP10 with water until external backfilling has been completed.**
- Backfill with approved granular material such as sand, compacted in 150mm layers to 90% maximum dry density, in accordance with AS 3798.
- **Do not use rock as backfill.**
- Backfill must be raised evenly around the tank, with a maximum backfill height differential of 400mm at any time.
- Ensure excavated material and backfill do not fall onto the lid of the tank, as debris may enter the tank and clog the diffusers and irrigation pump.
- The inlet connection is a standard 100mm sewer pipe.
- The outlet connection is a standard female 40mm pressure elbow on top of the tank.
- Electrical connections are 240 volts for pumps and 12 volts for the alarm panel.
- **If the tank is not filled with water, it could hydraulically lift out of the ground in wet conditions.**

Failure to strictly follow these instructions will void the warranty. Please refer to the warranty details.



Electrical

All electrical connections must be carried out by licensed and experienced tradespeople.

Within the premises' switchboard, we recommend using an independent and dedicated 16 Amp (minimum) circuit, serviced by its own ELCB (residual current device), to supply power to your Ri-Treat EP10.

Note: Ri-Industries' alarm panels are 12-volt AC powered from a transformer within the control box mounted on top of the tank. The green light indicates that power is supplied to the system. The alarm panel features low voltage operation for safety and an automatic reset to minimise inconvenience.

Below is a diagram for the electrical installation:

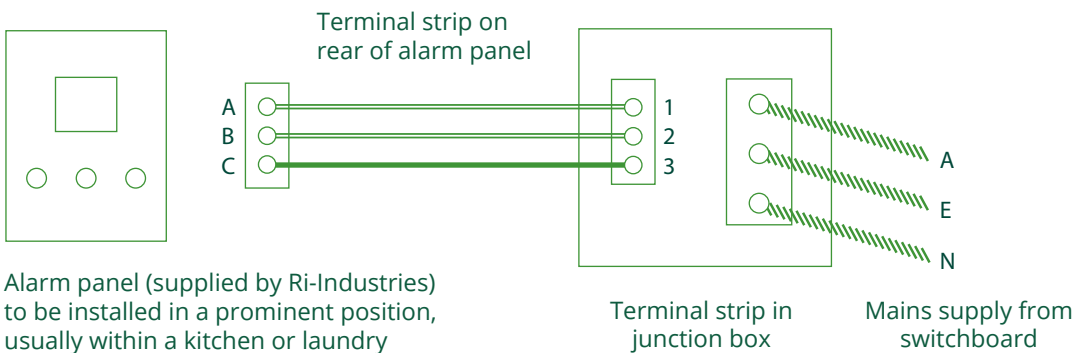
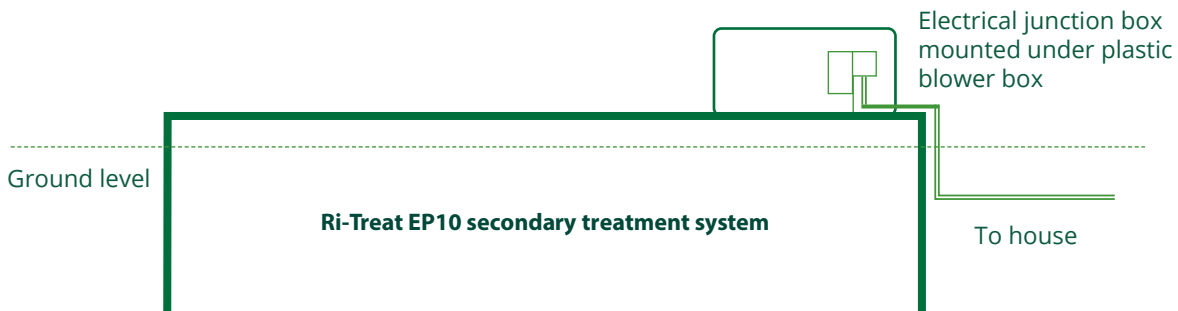

Commissioning

The Ri-Treat EP10 is supplied fully commissioned and ready for use. Once installed, it is essential to provide electrical power to the system and fill the unit to the correct levels with clean water.

The recommended operating temperature range, when fully buried, is between -1°C and 41°C ambient air temperature.

Steps to complete before using the unit

Installer's responsibility:

- Fill the Ri-Treat EP10 to **50% capacity** with clean water or until both sides of the aeration filter media are covered.
- Connect the drain from the residence.
- Install and connect the outlet pump to the irrigation/dispersal field.
- Ensure proper placement of sprinklers and drippers for irrigation.
- Connect electrical power.

Owner's responsibility:

- Contact an accredited service agent to arrange ongoing servicing of the unit. If you are unsure who the service agent is, please contact Ri-Industries on (08) 8444 8100.



Servicing

The Ri-Treat EP10 should only be serviced by an SA Health accredited service agent. Contact Ri-Industries for a service agent in your area. Before servicing, refer to warranty details.

Air blower and electrical check

- Remove the plastic cover over the air blower and electrical control box.
- Inspect for chafed electrical cables and clear any obstructions from the air blower intake.
- Remove, clean, or replace the air filter as needed.
- Ensure the joining tube is flexible and undamaged; replace if necessary.
- Sweep out any debris under the plastic cover.

Septic chamber inspection

- Using the 'swift lift' 1.3t, lift the small concrete cover above the septic chambers.
- Check if liquid levels on both sides of the baffle are similar; clear any blockages if levels differ.
- Observe the crust thickness in the primary septic chamber - it indicates system health and potential overload.
- A natural crust forms over time and is broken down by bacteria, but overloading can slow this process.
- Excessive crust may require removal via vacuum tanker.
- Natural bacteria can be affected by:
 - Excess water or biological load
 - Antibacterial substances, antibiotics, chemicals, petrochemicals, or excess oils/fats
- The system is designed to recover from minor short-term overloads.

Filter maintenance

- Remove the large septic-to-aeration chamber cover.
- Remove and hose down the filter and check for blockages; replace annually or as needed.

Aeration chambers

- Remove the large centre square cover to inspect the two aeration chambers.
- Ensure airflow is balanced in both chambers; adjust using the red-handled taps if needed.
- If excessive scum has developed, vacuum and return it to the primary or inlet chamber (inlet chamber is best, below the PVC cover).
- Remove the inlet cover to check the inlet to the system is not blocked.

Sludge return check

- Check the sludge return at the outlet to the aeration chamber to ensure it is not blocked, as this can cause the system to flood.
- Clear any blockages using a pressure garden hose, flushing through the inlet pipe and bio-medium within the unit.
- Within this return, a sludge return system sends trapped scum back to the inlet. This is controlled by an air tap (located inside the tank).
- Open the air tap fully for several minutes to clear the chamber, then adjust it to allow a slow bubbling flow. This can be checked by observing the water return flow at the tank inlet.
- Remove the filter from the filter housing, hose it down, and check for blockages. Replace the filter annually or as required.

Filter and bio-medium maintenance

- Bio-medium cubes may accumulate biomass over time. If excessive, use a pressure garden hose to wash off the build-up.
- Dislodging biomass releases debris that must be transferred back to the primary chamber by vacuum or the internal sludge return.
- Avoid flushing too much biomass at once, as this may block the septic return and cause system flooding. A wet and dry vacuum can be useful for removal.

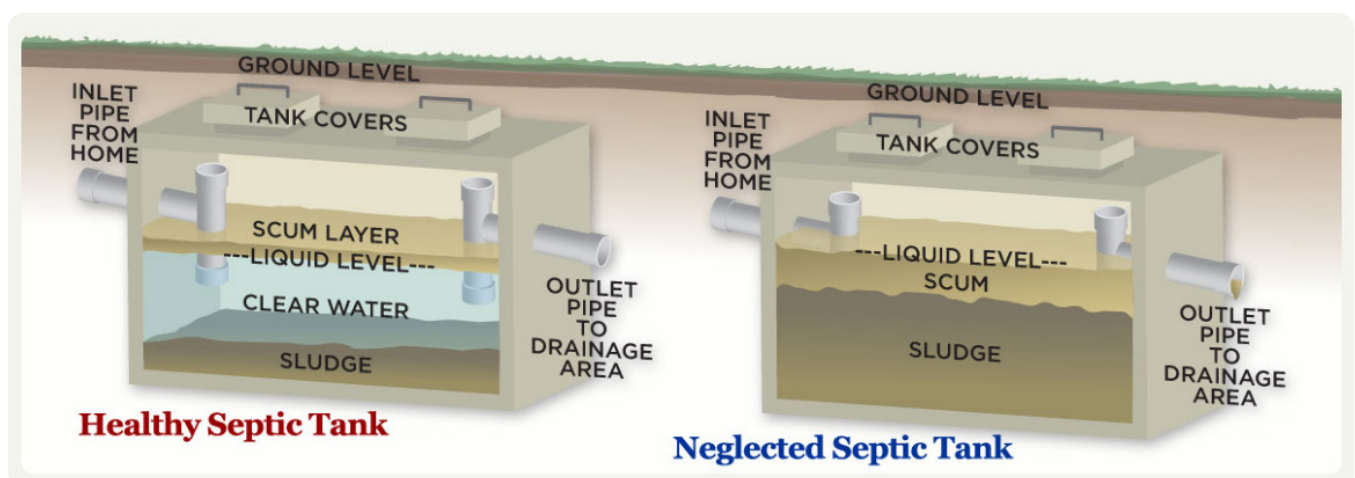

Settlement chamber maintenance

- From the aeration chamber, liquid flows into the settlement chamber.
- This chamber has a sludge return system that redirects floating and settled scum back to the inlet. This is controlled by an air tap (below the PVC inspection cover).
- Open the air tap fully for several minutes during servicing to clear most of the scum and sludge.
- Adjust the tap to allow a slow bubbling flow, and check by observing the return flow at the tank inlet.

Pump-out chamber inspection

- Remove the final concrete cover to access the pump-out chamber.
- Liquid from the settlement chamber flows through the chlorine canister and is stored here for automatic irrigation.
- Check the liquid level, pump, alarm cables, and clarity of the liquid.
- Normally, the liquid should be clear enough to see several hundred millimetres in depth, though this is only a general guide to quality.



Tests to be performed as part of a regular service

Liquid sample testing

- Take a sample of liquid from the first sprinkler by tripping the pump float to discharge.
- Collect enough liquid to fill a turbidity tube or large beaker.
- Perform a pH test and residual chlorine test using the appropriate swimming pool test kits.

Turbidity test

- Use a turbidity tube to assess liquid clarity at varying depths.
- Record the corresponding numbers for clarity and calculate the probable B.O.D.S. (biochemical oxygen demand score).

Temperature check

- Use a thermometer to measure the temperature of the primary and aeration chambers.
- High temperatures can reduce oxygen absorption, leading to poor wastewater quality.

Dissolved oxygen test

- Use a dissolved oxygen meter to compare oxygen levels in the primary and aeration chambers.
- Low readings in both chambers may indicate an issue that needs further investigation.

pH testing

- Check pH levels, as they indicate system stability.
- A neutral pH is ideal; excessively acidic or alkaline conditions can cause system malfunction and offensive odours.

System adjustments

- On start-up, slight odours may occur. Adding a small amount of Dynamic Lifter (soaked in water) to the system inlet may help kick-start the process.
- If the system becomes too acidic, add a small amount of dehydrated lime to raise the pH.
- If the system becomes too alkaline, add a small amount of hydrochloric acid, but handle it with care.

System operation and final checks

The system operates naturally and typically requires minimal chemical additions.

- Top up the chlorine using stabilised chlorine tablets only (tri-chloro-iso-cyanuric acid).
- Replace all covers.
- Replace the plastic blower box cover.
- Check that the land application area (irrigation area) is functioning correctly and that the pump is discharging properly.
- Ensure the “reclaimed water” warning signs are positioned, mounted, and clearly visible.
- Wash hands thoroughly with antiseptic or disinfectant hand cleaner.

Service report

Complete a service report detailing:

- Test results
- Any defects found
- General condition of the system

Leave a copy of the report on-site with the owner or authorised land agent, send a second copy to Council, and retain a third copy for the service agent’s records.

If you have any problems or questions about the system, contact Ri-Industries.

Recommended maintenance tools

- Swift lift 1.3t lifting clasp to remove the concrete covers
- Cordless drill or screwdriver with Phillips head adaptor to remove the screws on the plastic blower box and PVC trap screws
- Medium-sized flat head screwdriver
- Broom
- Wet and dry vacuum
- Rubber gloves

Recommended instruments

- Turbidity tube
- Swimming pool pH test kit
- Swimming pool chlorine test kit
- Floating thermometer
- Dissolved oxygen meter
- Sludge judge

Ri-Treat and Ri-Scape Bristle Filter

The Ri Bristle Filter comes standard in our Ri-Treat and Ri-Scape tanks and can be incorporated into septic and holding tanks to enhance effluent quality.

We recommend cleaning the filter quarterly and replacing it annually or as needed.

Poor maintenance or factors such as garbage disposals or excessive laundry may require more frequent inspections, servicing, or replacement of the filter.

Features

- Effectively filters out hair, lint, tissue, seeds, and other debris that can clog pumps and soakage trenches
- Provides excellent filtration performance
- Offers over 300 cubic inches of open area to minimise clogging
- Flexible design allows installation in hard-to-reach tees, baffles, and similar components
- Constructed from twin 2.5 mm stainless wire with black UV-stable polypropylene bristles for superior filtration and durability

Installation and removal

To install:

1. Push the Ri Bristle Filter into the top of the PVC tee inside the tank until the 90-degree wire handle rests on the top of the tee.
2. The filter is now installed, as shown in the picture.

To remove for cleaning or replacement:

1. Pull up on the wire handle to remove the filter.
2. Hose down the filter over the inlet chamber to clean it.
3. If replacing, place the used filter in a plastic bag for proper disposal.

To order

Please contact Ri-Industries

- sales@ri-industries.com.au
- 8444 8100



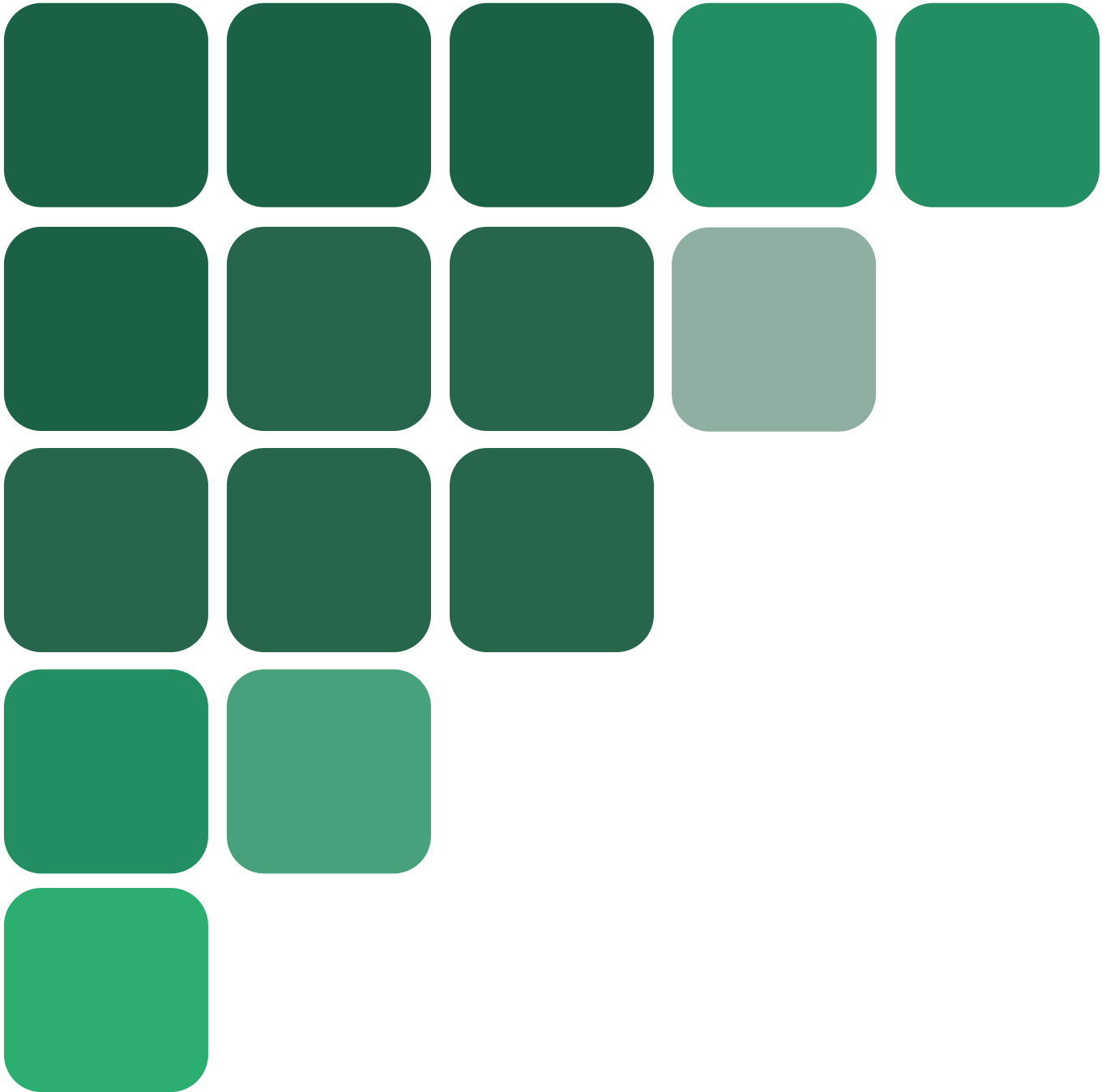

Ri-Industries

24-30 Davis Street, Wingfield,
South Australia, 5013

(08) 8444 8100
sales@ri-industries.com.au

ri-industries.com.au

ABN 81 007 647 323 | APRIL 2025

